

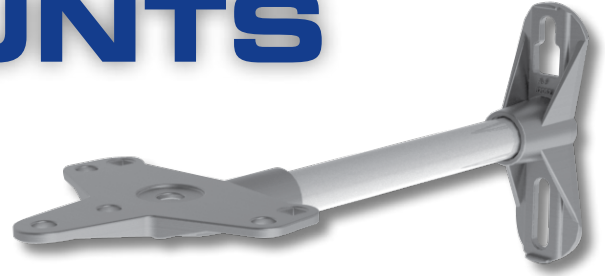

ALUMA-FORM®

# FIBERGLASS EQUIPMENT MOUNTS

## Single Phase/Clover Leaf 7-Hole 0° Mount



### Material Specifications

#### Pole Gain

- 65-45-12 Ductile Iron, hot-dipped galvanized per ASTM A153 (6" to 8" mounting centers)
- Accepts 5/8" pole mounting hardware
- Can be banded using the Aluma-Form Bolt-A-Band banding system

#### End Fitting

- 65-45-12 Ductile Iron, hot-dipped galvanized per ASTM A153

#### Fiberglass Rod

- 1-1/2" diameter Super-Smooth, proprietary veiled gray polyester rod with added ultraviolet protection

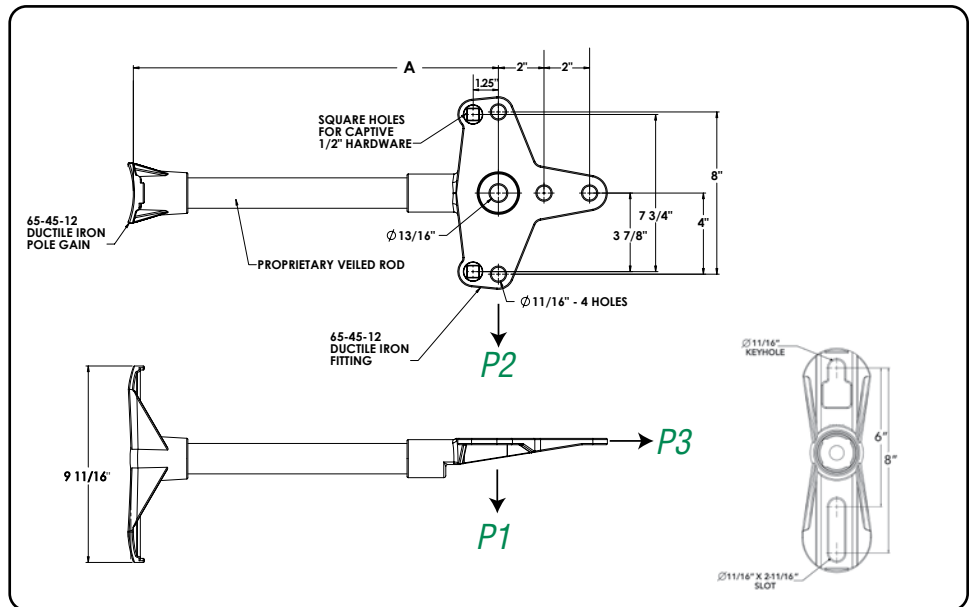

| Catalog Name     | Rod Diameter | Standoff Length, A <sup>1</sup> | Hardware <sup>2</sup> | Ultimate Load |          |          | Weight   |
|------------------|--------------|---------------------------------|-----------------------|---------------|----------|----------|----------|
|                  |              |                                 |                       | P1 (lbs)      | P2 (lbs) | P3 (lbs) |          |
| F1CA-MV-H12-C7   | 1-1/2"       | 12"                             | No                    | 1,800         | 1,400    | 10,000   | 7.8 lbs. |
| F1CA-MV-H15-C7   | 1-1/2"       | 15"                             | No                    | 1,500         | 1,150    | 10,000   | 8.2 lbs. |
| F1CA-MV-H18-C7   | 1-1/2"       | 18"                             | No                    | 1,200         | 900      | 10,000   | 8.6 lbs. |
| F1CA-MV-H24-C7   | 1-1/2"       | 24"                             | No                    | 900           | 700      | 10,000   | 9.4 lbs. |
| F1CA-MV-H12-C7-H | 1-1/2"       | 12"                             | Yes                   | 1,800         | 1,400    | 10,000   | 8.2 lbs. |
| F1CA-MV-H15-C7-H | 1-1/2"       | 15"                             | Yes                   | 1,500         | 1,150    | 10,000   | 8.7 lbs. |
| F1CA-MV-H18-C7-H | 1-1/2"       | 18"                             | Yes                   | 1,200         | 900      | 10,000   | 9.1 lbs. |
| F1CA-MV-H24-C7-H | 1-1/2"       | 24"                             | Yes                   | 900           | 700      | 10,000   | 9.9 lbs. |

#### Notes:

1. Custom lengths available, contact factory or local sales representative.
2. Standard hardware includes captured 1/2" x 2" carriage bolt, 1/2" hex nut, 1/2" lock washer, & 1/2" star washer.